

FUN WORLD 3D

INSTRUCTION MANUAL



1.20 cubic inch displacement 4 stroke (glow)
Radio required : 8 channels, 8 servos airplane radio

Specifications

Wing Span	70.5 in / 1790 mm
Wing Area	1392 sq in / 89.8 sq dm
Flying Weight	9.5 lbs / 4300 g
Fuselage Length	70.0 in / 1780 mm

* Specifications are subject to change without notice. *

Warning! This model is not a toy.

It is designed for maximum performance. Please seek advice if one is not familiar with this kind of engine powered precision model. Operating this model without prior preparation may cause injuries. Remember, safety is the most important thing. Always keep this instruction manual at hand for quick reference.



**THE WORLD MODELS
MANUFACTURING CO. LTD.**

FACTORY PRE-FABRICATED
ALMOST-READY-TO-FLY (ARF) SERIES
MADE IN CHINA
www.theworldmodels.com

FUN WORLD 3D

INDEX

BEFORE YOU BEGIN -----	P. 1
PARTS LIST -----	P. 2
ASSEMBLY -----	P. 3-12
SAFETY PRECAUTIONS -----	P. 12

BEFORE YOU BEGIN

- 1** Read through the manual before you begin, so you will have an overall idea of what to do.
- 2** Check all parts. If you find any defective or missing parts contact your local dealer. Please DRY FIT and check for defects for all parts that will require CA or Epoxy for final assembly. Any parts you manufacturer will replace any defective parts, but will be difficult to extend to the good parts that are good before gluing to defective parts during assembly.
- 3** Symbols used throughout this instruction manual comprise of the following.



Apply epoxy glue.



Apply instant glue.
(C.A. glue , super glue.)



Assemble left and right
sides the same way.



Ensure smooth non-binding
movement while assembling.



Peel off shaded portion
covering film.



Cut off shaded portion.



Drill holes with the specified
diameter (here: 3 mm).



Must be purchased separately!



Pay close attention here!

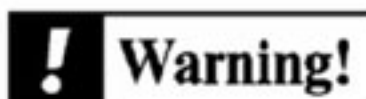

Do not overlook this symbol!



Pierce the shaded portion
covering film.

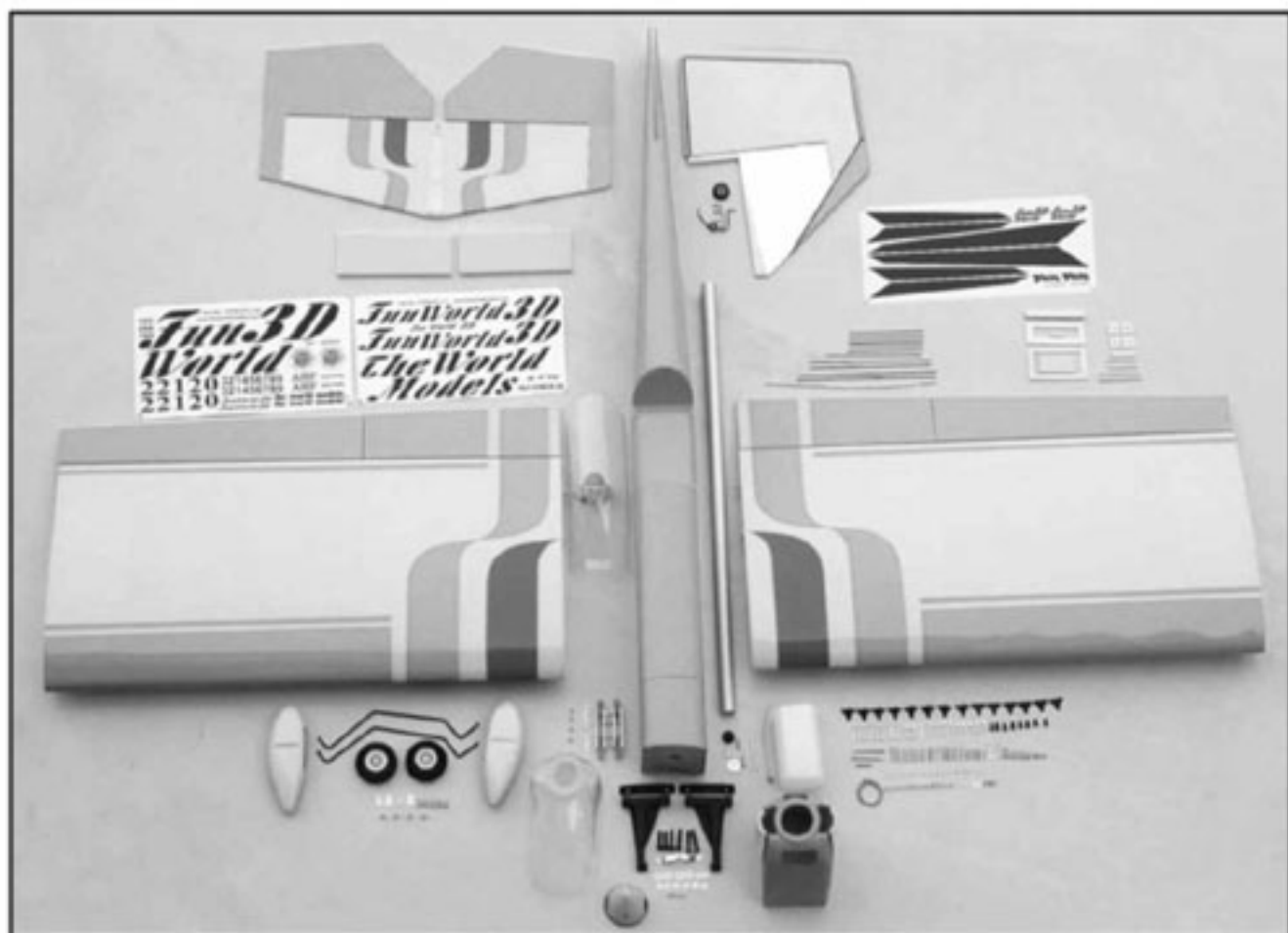

Parts List

1. FUSELAGE -- 1 pc.
2. MAIN WING -- 1 pair
3. STABILIZER & ELEVATOR -- 1 set
4. VERTICAL FIN & RUDDER -- 1 set
5. PILOT (# PC001063 B) -- 1 pc.
6. CANOPY -- 1 set
7. ENGINE MOUNT PL5111-020 -- 1 set
8. FUEL TANK 450cc -- 1 set
9. COWLING -- 1 pc.
TRANSPARENT 3D TEMPLATE -- 1 pc.
10. SPINNER Ø70mm -- 1 pc.
11. SPONGE 10 x 80 x 200mm (For Radio Equipment) -- 2 pcs
12. MAIN LANDING GEAR -- 2 pcs
13. MAIN WHEEL Ø 70mm -- 1 pair
14. WHEEL COVER -- 1 pair
15. TAIL LANDING GEAR -- 1 set
16. TAIL WHEEL Ø 30mm -- 1 pc.
17. METAL ROD, PUSHROD & PULLWIRE:--
METAL ROD Ø1.8 x 210mm w/Threads
(For Elevator & Fuselage) -- 2 pcs
METAL ROD Ø1.8 x 240mm w/Threads
(For Elevator & Vertical Fin) -- 2 pcs
RIGGING COUPLER Ø1.8 x 27mm w/Threads
(For Rudder) -- 2 pcs
RIGGING Z BEND Ø1.8 x 27mm (For Rudder) -- 2 pcs
METAL ROD Ø1.8 x 130mm w/Threads
(For Elevator, Aileron & Flap) -- 5 pcs
METAL ROD Ø1.8 x 170mm w/Threads (For Elevator) -- 1 pc.
WIRE Ø0.8 x 850mm (For Rudder) -- 2 pcs
COPPER TUBE d2 x D 2.4 x 8mm (For Rudder) -- 4 pcs
18. THROTTLE PUSHWIRE Ø 1.2 x 300mm
w/Plastic tube d2 x D3 x 160mm -- 1 set
19. WOODEN PARTS : --
BALSA 5 x 5 x 50 (For Throttle Servo) -- 2 pcs
BALSA 5 x 5 x 70 mm (For Rudder Servo) -- 2 pcs
BALSA 10 x 10 x 100 mm (For Fixing Fuel Tank) -- 1 pc.
PLYWOOD 3 x 10 x 21 mm (For Throttle Servo) -- 1 pc.
PLYWOOD 3 x 10 x 41 mm (For Throttle Servo) -- 1 pc.
PLYWOOD 3 x 10 x 96 mm (For Rudder Servo) -- 2 pcs
- PLYWOOD 3 x 41 x 100 mm (Throttle Servo Stand) -- 1 pc.
PLYWOOD 3 x 31 x 61 mm (Elevator Servo Stand) -- 1 pc.
PLYWOOD 3 x 61 x 100mm (Rudder Servos Stand) -- 1 pc.
20. PLASTIC PARTS : --
CLEVIS -- 8 pcs
SILICON GROMMET d1.5 x D6.5mm (For Canopy & Cowling) -- 9 pcs
STRAPER -- 6 pcs
TRI - HORN M3 x 14mm (L) -- 6 sets
TRI - HORN M3 x 14mm (L) (w/o Base For Rudder) -- 2 sets
PLATE (Main Landing Gear & Wheel Cover) -- 4 pcs
21. METAL PARTS : --
LINKAGE CONNECTOR -- 1 sets
COLLAR 2.6mm -- 1 set
COLLAR 4.6mm -- 4 sets
ALUMINUM PLATE 2 x 12 x 75mm (For Engine Mount) -- 1 pc.
WING TUBE Ø25 x 784mm -- 1 pc.
NUT 2mm -- 6 pcs
NUT 3mm -- 4 pcs
SCREW PA3 x 12mm -- 10 pcs
SCREW PA2.3 x 12mm -- 1 pc.
SCREW PA3 x 40mm -- 1 pc.
SCREW PM2 x 16mm -- 6 pcs
SCREW PM2 x 20mm -- 15 pcs
SCREW PM2 x 16mm -- 9 pcs
SCREW PM2 x 25mm -- 3 pcs
SCREW PM3 x 16mm -- 2 pcs
SCREW PM3 x 25mm -- 1 pc.
SCREW PM3 x 40mm -- 1 pc.
SCREW PWA2.3 x 8mm -- 5 pcs
SCREW PWA2.6 x 12mm -- 4 pcs
SOCKET HEAD SCREW M6 x 30mm -- 4 pcs
WASHER d3 x D7mm -- 4 pcs
WASHER d6 x D18mm -- 4 pcs
22. ANTI-VIBRATION MOUNT 4C - 120 -- 1 set
(INCLUDE: SOCKET HEAD SCREW M3 x 35mm -- 4 pcs
SCREW KM3 x 20mm -- 8 pcs
WASHER d3 x D12mm -- 8 pcs
NYLON INSERT LOCK NUT 3mm -- 12 pcs
23. FUEL TUBE Ø6 x 5mm : -- 14 pcs
24. DECALS : -- 1 set

1 Aileron

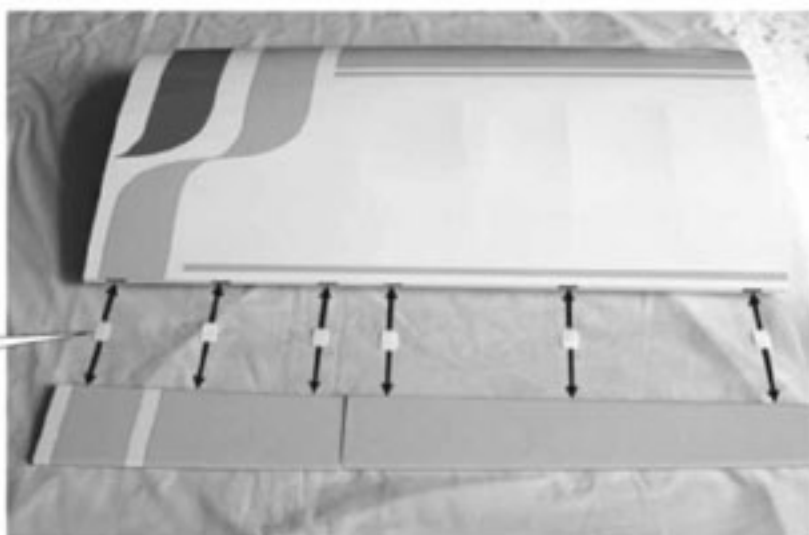

L/R

2 Aileron Servos

PM2 x 20mm Screw

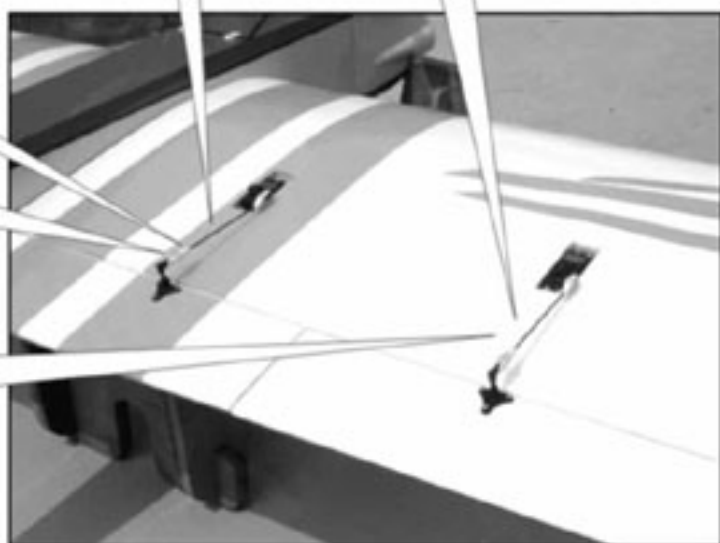
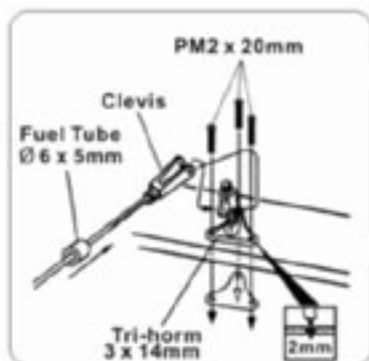
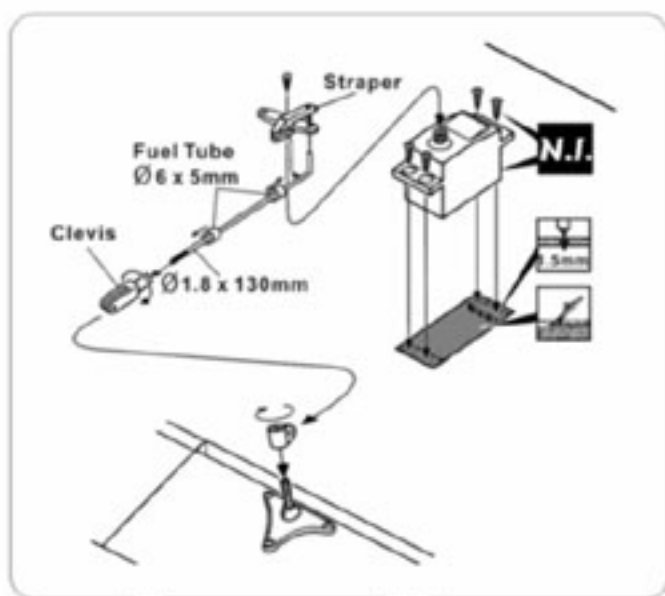

L/R

3 Landing Gear

PA3 x 12mm Screw



8

3mm Set Screw



4

4.6mm Collar



4

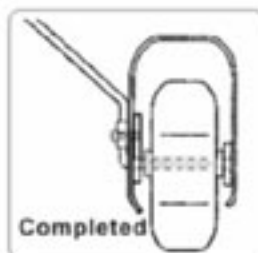
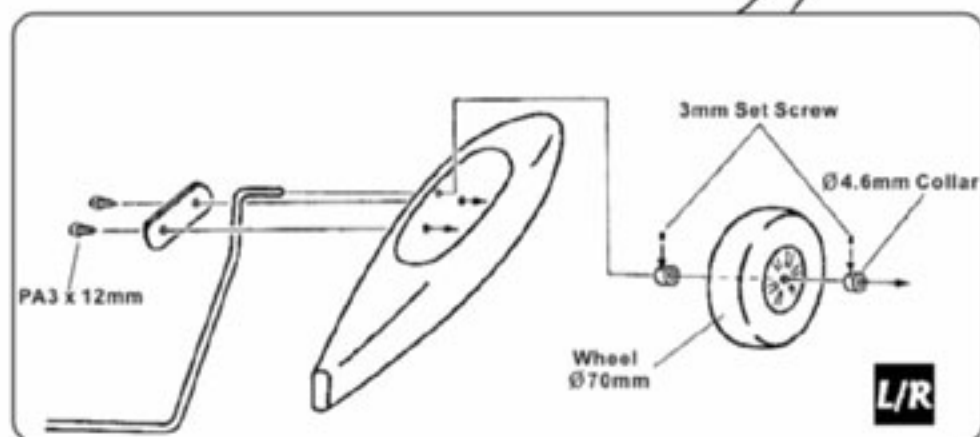
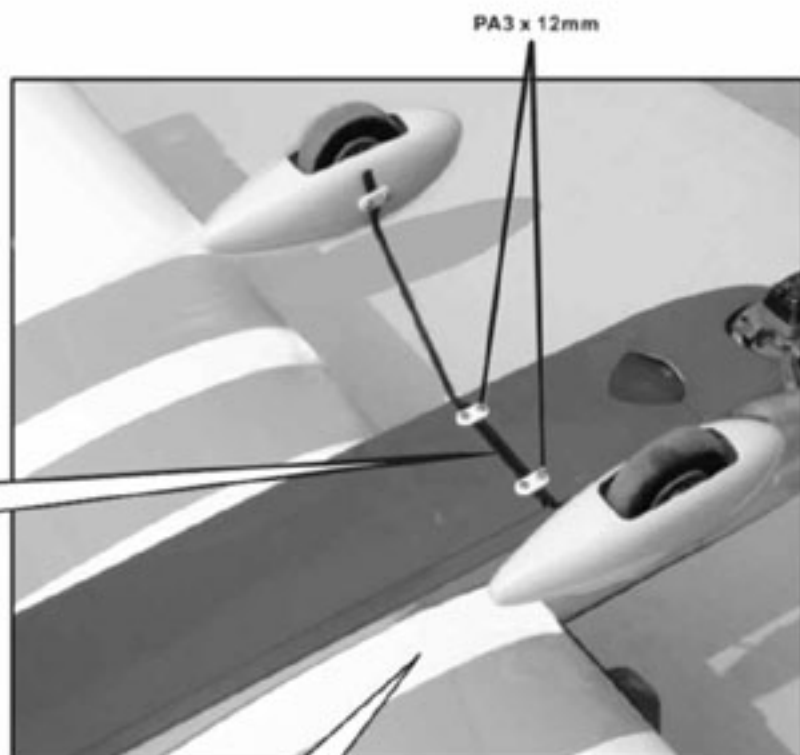

4 Engine Mount

M6 x 30mm Screw



4

d6 x D12mm Washer



4

d6 x D12mm
M6 x 30mm
Engine Mount
PL5911120



● Apply thread locker to screws.

! Blind nuts are off-centered to keep the spinner at the fuselage axis.

5 Fuel Tank



Balsa 10 x 10 x 100mm

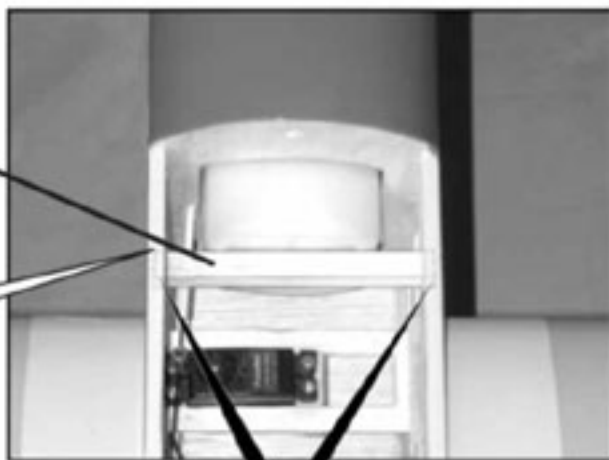

C.A.

6 Stabilizer & Elevator

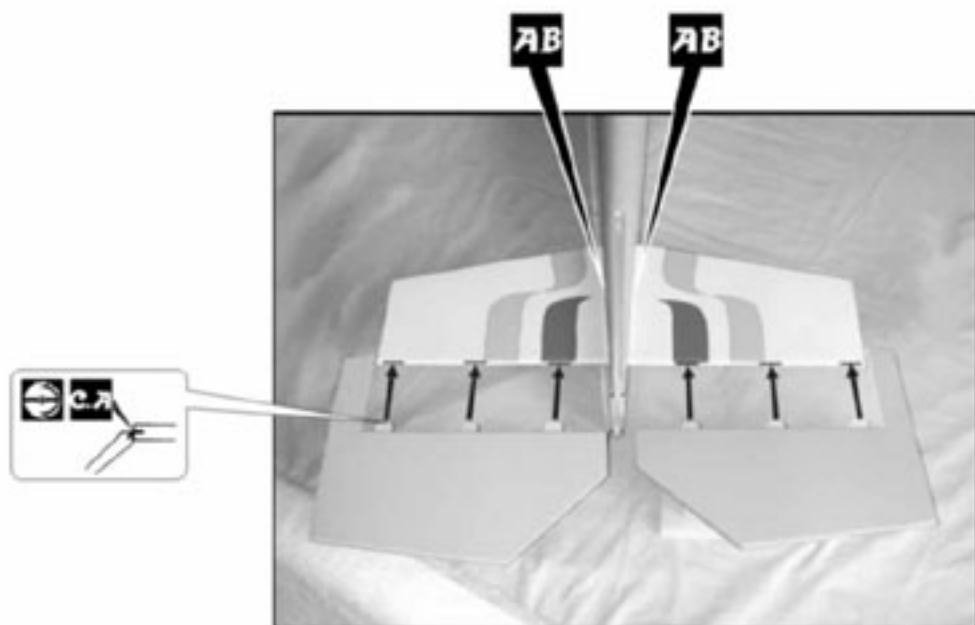
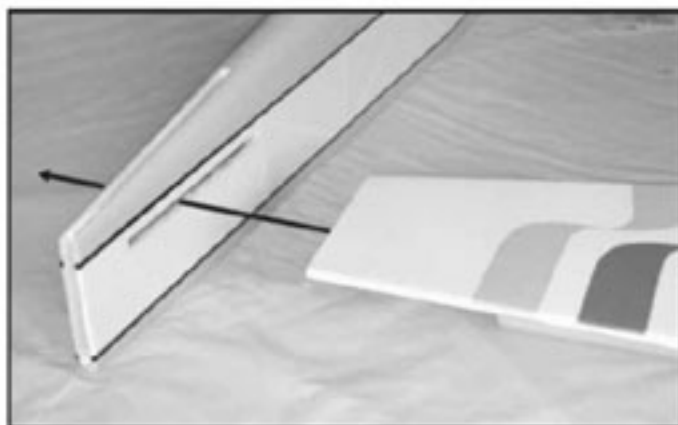
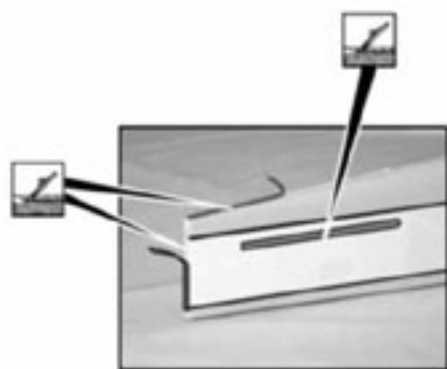

7 Vertical Fin & Rudder

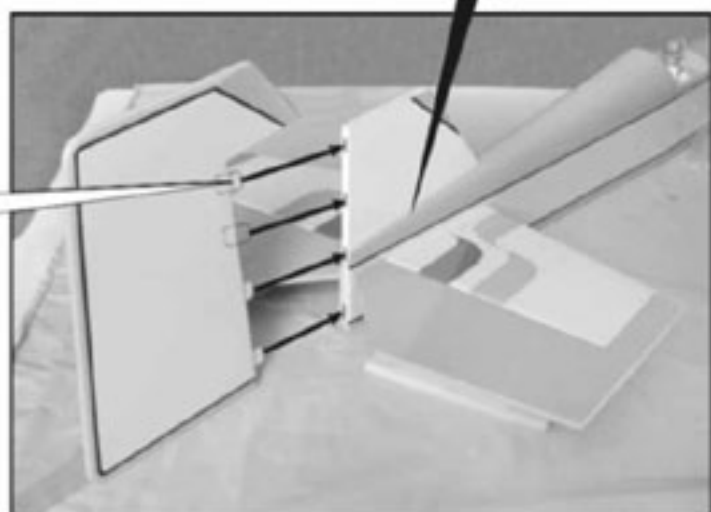
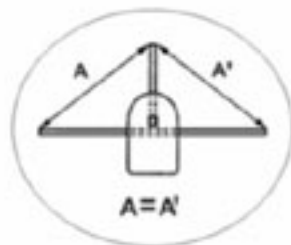

8 Tail landing Gear

PA3 x 12 mm Screw



3mm Set Screw



2.6mm Wheel Collar



Ø 30mm



PA3 x 12 mm

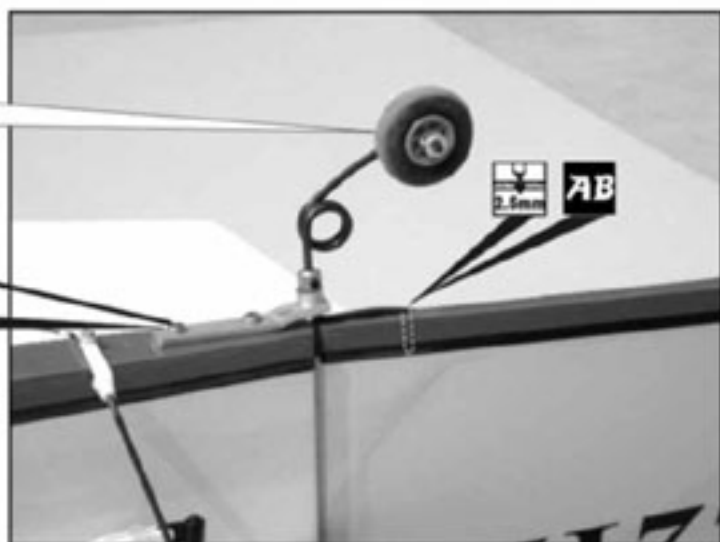
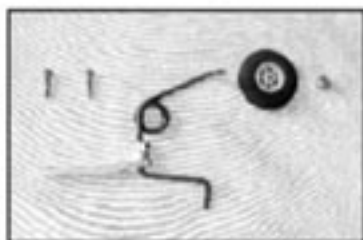

9 Rudder Pullwire

PM2 x 20mm Screw



PM2 x 25mm Screw



2mm Nut



Metal Rod
Ø1.8 x 240mm



PM2 x 25mm

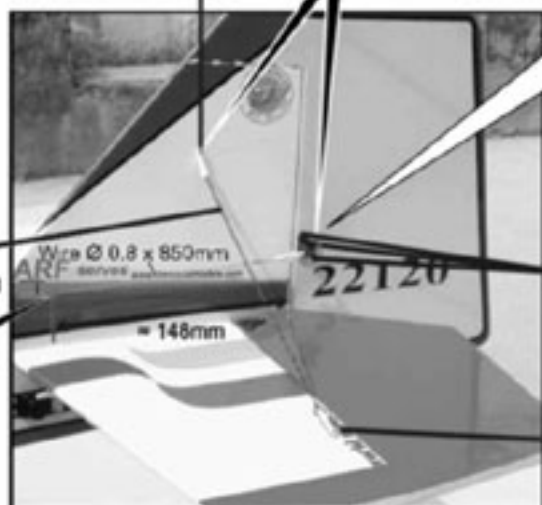

Copper Tube

Clevis



Rigging Coupler

Ø1.8 x 27mm

w/Threads



PM 2 x 20mm

2mm Nut

PM2 x 25mm



10 Elevator Pushrod

PM2 x 16mm Screw

6

2mm Nut

2

PA2.3 x 12mm Screw

1

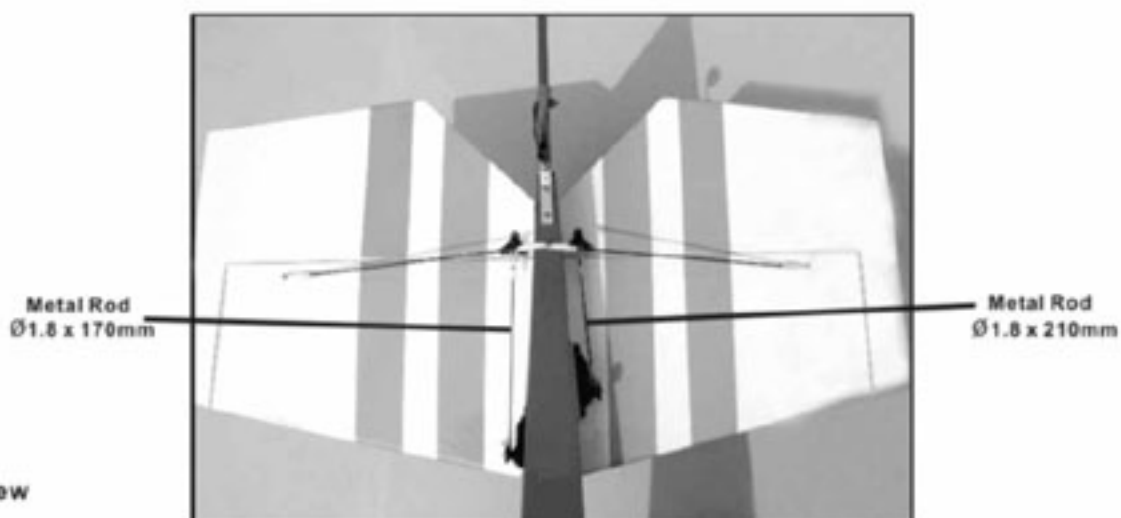
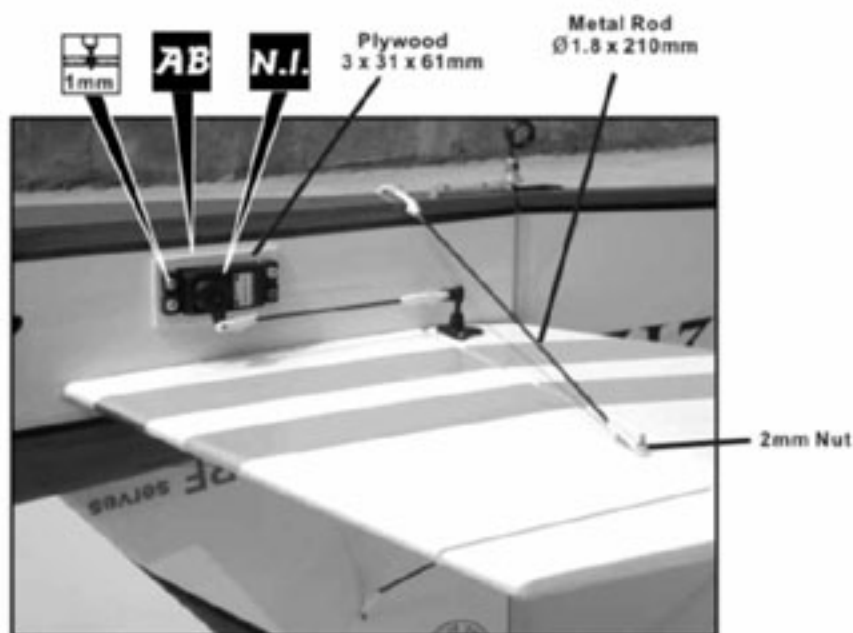
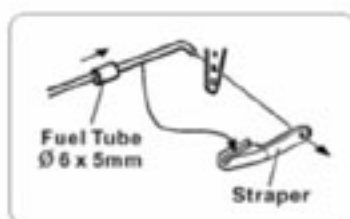
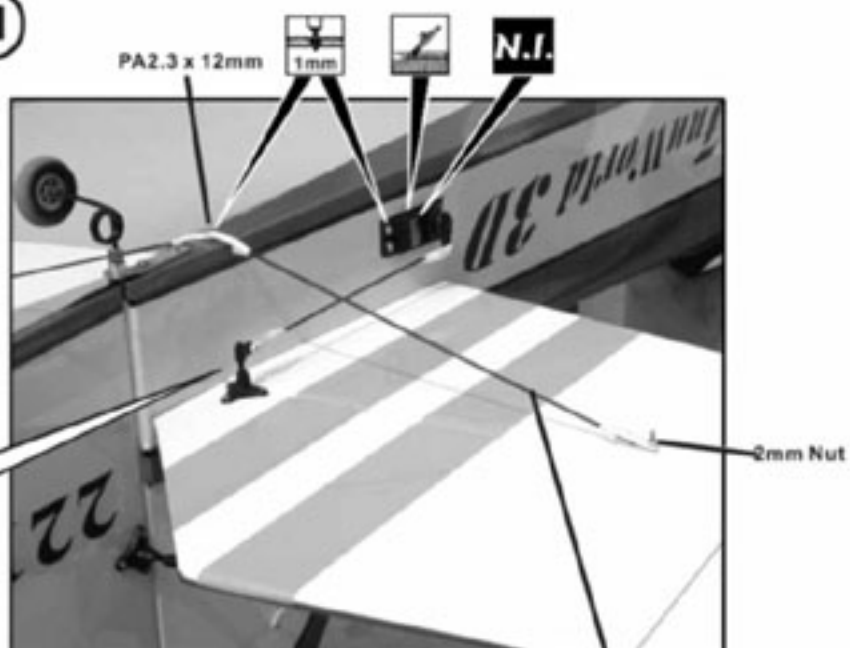
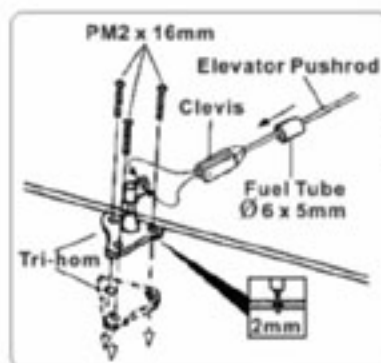

● Bottom View

11 Servo Set

LINKAGE CONNECTOR

3 x 3mm Set Screw 1

Linkage Connector 1

2mm Nut 1

2mm Washer 1

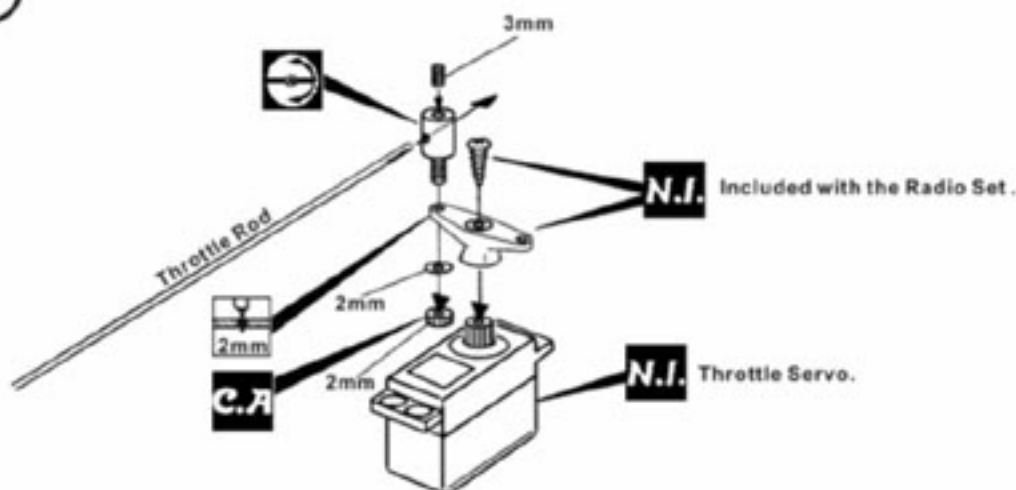

! Please refer to attached sheet for linkage connector installation.

12 Servos

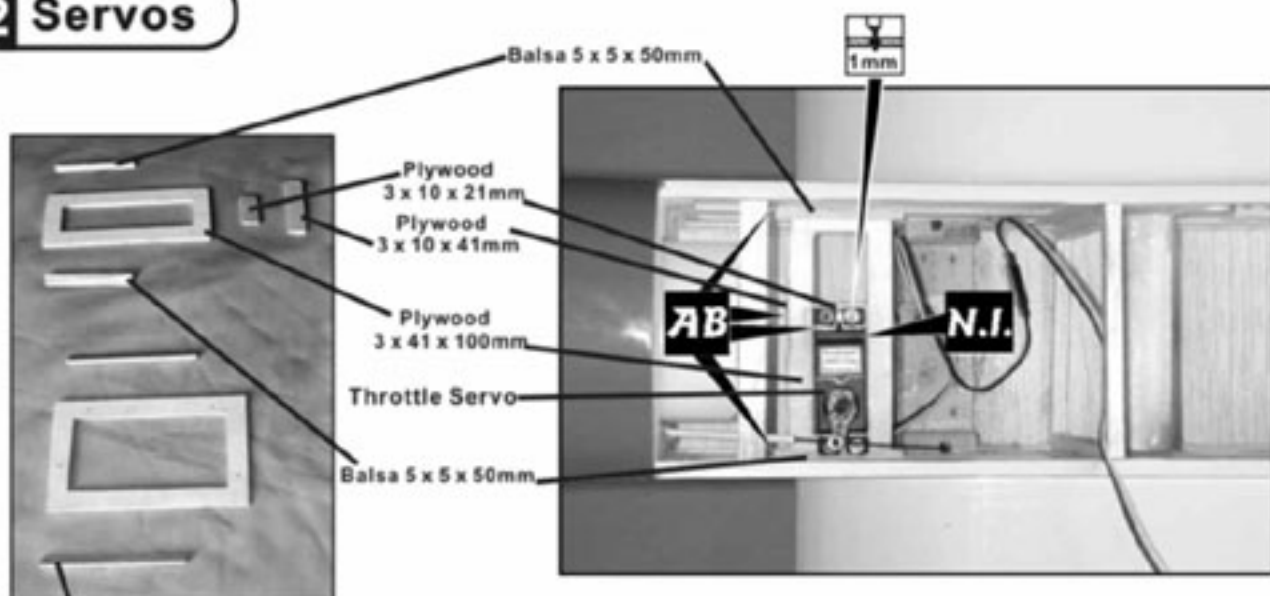

• Install and arrange the servo as shown in the diagram.

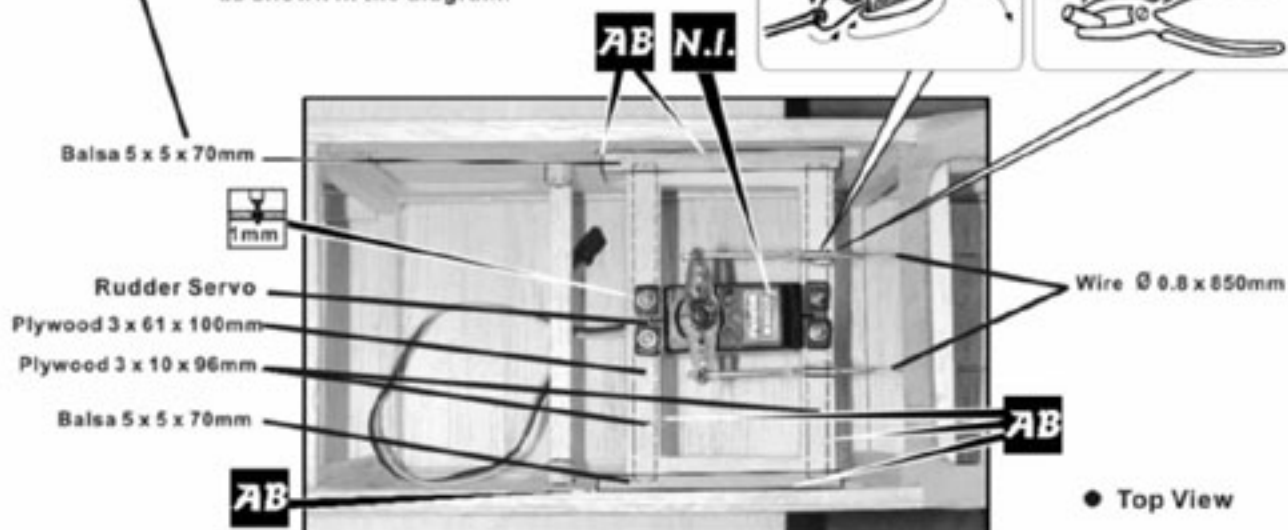

13 Engine

M3 x 35mm Screw



d3 x D12mm Washer



3mm Nylon Insert Lock Nut



KM3 x 20mm Screw

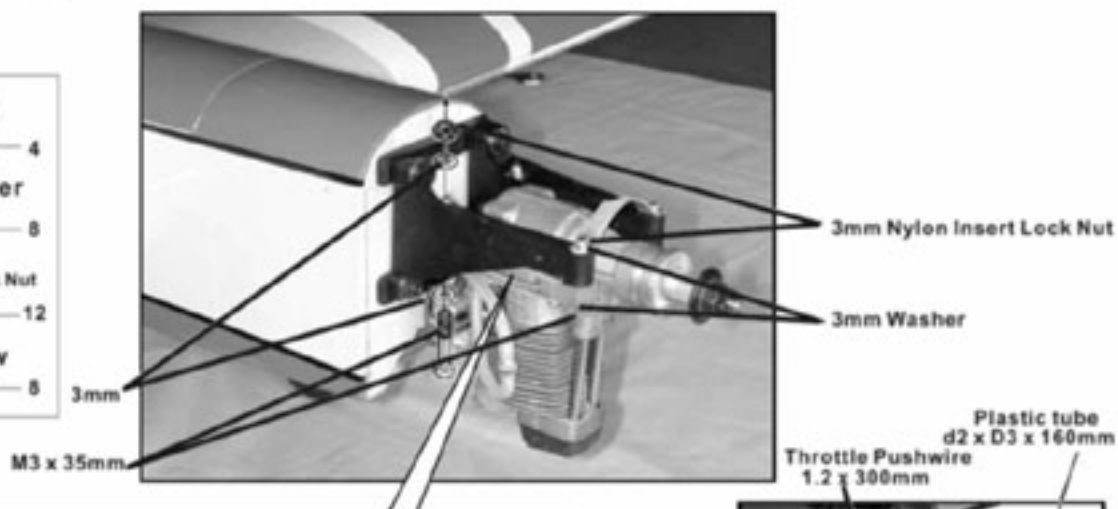

ANTI - VIBRATION MOUNT INSTALLATION

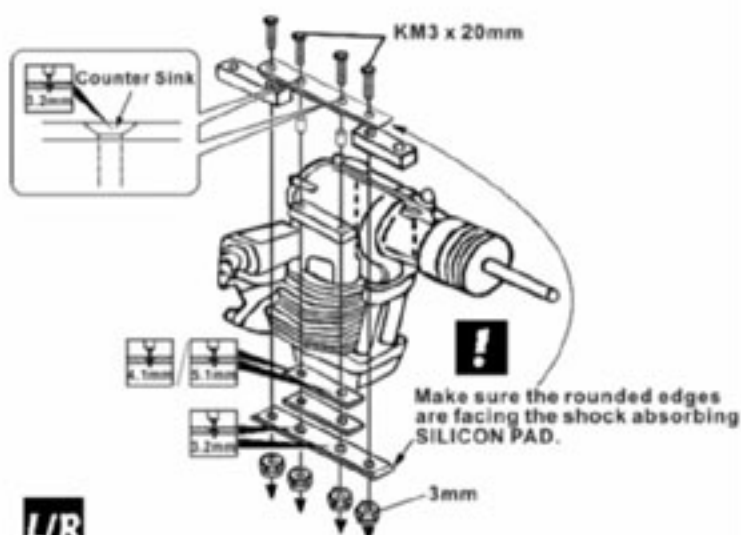

L/R



! Illustration is for inverted mounting. You can mount the engine upright or sideways simply by rotation the engine mount. Thrust angles will not be affected.

• Install Engine position

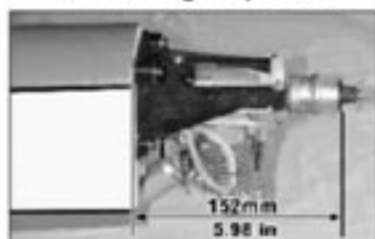

14 Cowling

PWA2.6 x 12mm Screw



d1.5 x D6.5mm Silicon Grommet

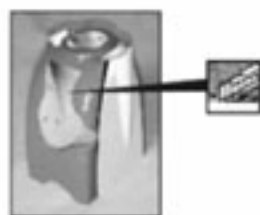

PWA2.6 x 12mm
Silicon Grommet
d1.5 x D6.5mm



• First insert the grommet to the cowling then apply screw.

15 Main Wing

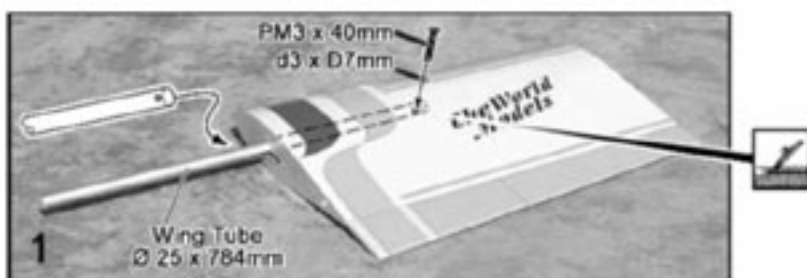
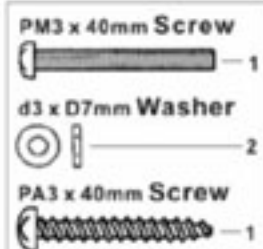

Step 1. Insert the aluminum wing tube with the pre-drilled hole end into the right wing. Align the lines marked at the wing root and wing tube and apply the PM3 x 40 machine screw through the pre-drilled hole on top of the wing. (please confirm the alignment of the hole by putting a 2.5mm diameter rod through the pre-drilled wing hole before applying the screw) The hole on the wing tube is pre-threaded, do not over tighten the PM3 screw, the set up is for future removal of the wing.

Step 2. Install the right wing to the fuselage by inserting the wing tube (now attached to the right wing) through the fuselage, then install the left wing.

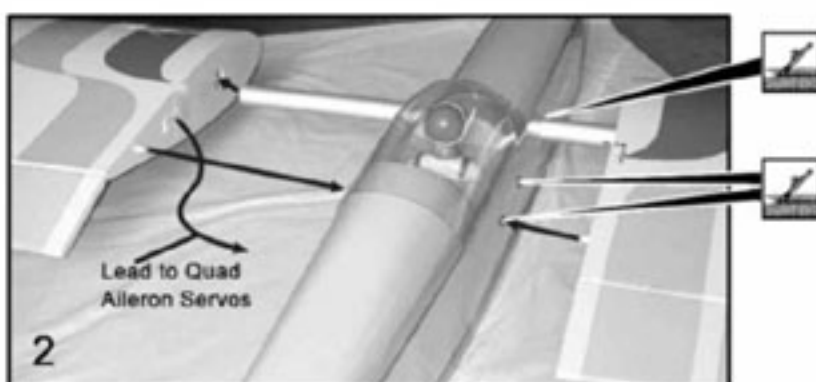

• Top View

2.5mm d3 x D7mm PA3 x 40mm



Step 3. Make sure the wings are resting against the fuselage tightly. Locate the pre - drilled 2.5 mm hole at top of left wing, and drill along with 2.5mm drill bit until it passes through the wing tube. Apply the PA3 x 40 self - tapping screw.

Note: It is recommended that the wing tube stays with the left wing, Removal of the wings could be achieved by removing the right wing machine screw, the right wing then the left with wing tube. If removal of wing tube from left wing is also required, it is recommended that instead of applying self - tapping screw in step 3, you pre - tap with M3 thread cutter and apply M3 machine screw.

16 Canopy

PM3 x 16mm Screw



d3 x D7mm Washer



PWA2.3 x 8mm Screw



d1.5 x D6.5mm Silicon Grommet



d3 x D7mm
PM3 x 16mm



• Apply double - sided tape



Silicon Grommet
d1.5 x D6.5mm

PWA2.3 x 8mm

1mm

L/R

• First insert the grommet to the canopy then apply screw.

17 Wing Setting

Adjust the wing and fuselage configuration as in the diagrams.



A = A'

B = B'

C = C'

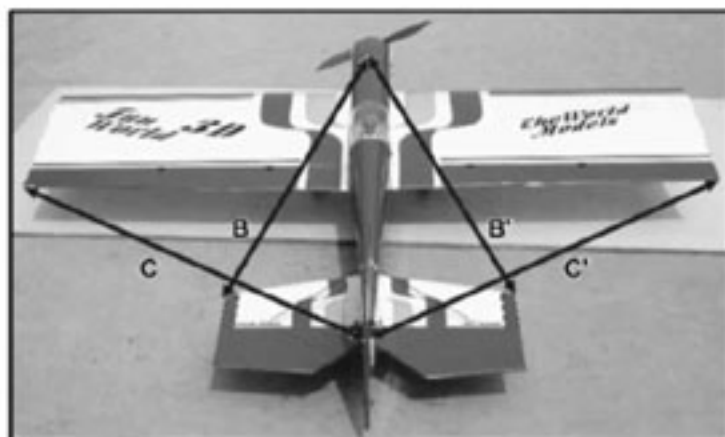
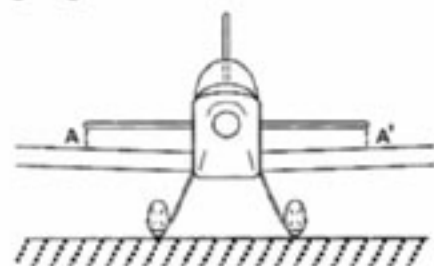

18 Control Throws

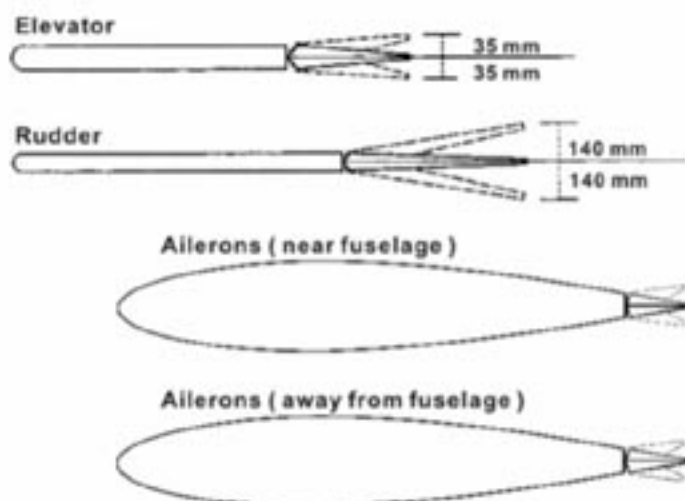

Adjust the control throws as shown in the diagram. These throws are good for general flying. You can adjust according to your personal preference.

19 C.G.

The ideal C.G. Position is 135mm (5.3 in) behind the leading edge measured at where the wing meets the fuselage. In order to obtain the C.G. specified, add weight to the fuselage or move the battery position. Check the C.G. before flying.

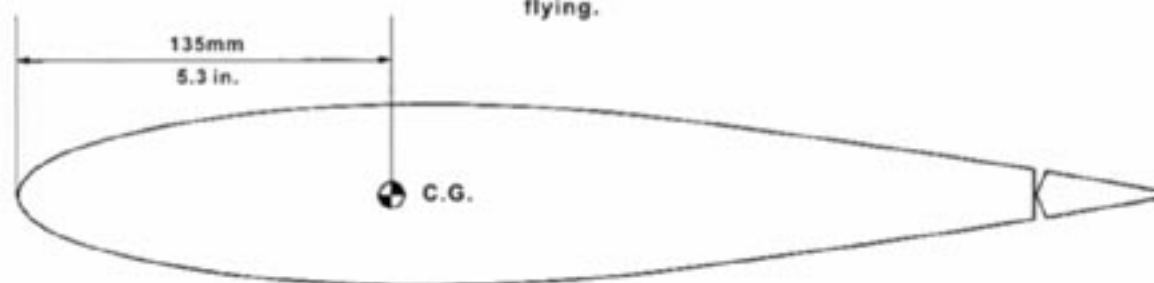

! Warning!

Important Safety Precautions

- # First time flyer should never fly by himself / herself. Assistance from experienced flyer is absolutely necessary.
- # Pre-flight adjustment must be done before flying, it is very dangerous to fly a badly pre-adjusted aircraft.
- # **FUN WORLD 3D** is specially designed to be powered by 1.20 4 stroke glow engine, using a more powerful engine does not mean better performance. In fact, over powered engine may cause severe damage and injuries.
- # Make sure the air field is spacious, never fly the plane too close to people and never get too close to a running propeller.
- # If you find wrinkles on the covering as a result of weather changes, you can use hot iron to remove the wrinkles. Please begin with lower temperature setting and gradually raise the temperature until the wrinkles are gone. Too hot an iron may damage the covering.
- # Check and re-tighten up all factory assembled screws, use thread locker if applicable.