

SPITFIRE

INSTRUCTION MANUAL



0.61 cubic inch displacement 2 stroke (glow)
0.70 cubic inch displacement 4 stroke (glow)
Radio required: 6 channels, 7 servos airplane radio

Specifications

Wing Span	63.0 in / 1600 mm
Wing Area	704 sq in / 45.4 sq dm
Flying Weight	7.5 lb / 3300 g
Fuselage Length	53.5 in / 1350 mm

Specifications are subject to change without notice.

Warning! This model is not a toy.

It is designed for maximum performance. Please seek advice if one is not familiar with this kind of engine powered precision model. Operating this model without prior preparation may cause injuries. Remember, safety is the most important thing. Always keep this instruction manual at hand for quick reference.



**THE WORLD MODELS
MANUFACTURING CO.,LTD.**

FACTORY PRE-FABRICATED
ALMOST-READY-TO-FLY(ARF)SERIES
MADE IN CHINA
www.theworldmodels.com

SPITFIRE

INDEX

BEFORE YOU BEGIN	-----	P.1
PARTS LIST	-----	P.2
ASSEMBLY	-----	P.3-12
SAFETY PRECAUTIONS	-----	P.12

BEFORE YOU BEGIN

- 1** Read through the manual before you begin , so you will have an overall idea of what to do.
- 2** Check all parts . If you find any defective or missing parts contact your local dealer. Please DRY FIT and check for defects for all parts that will require CA or Epoxy for final assembly. Any parts you find to be defective after the gluing process may be difficult to remove for warranty replacement. The manufacturer will replace any defective parts, but will be difficult to extend to the good parts that are good before gluing to defective parts during assembly.
- 3** Symbols used throughout this instruction manual comprise of the following:-

AB Apply epoxy glue.

C.A Apply instant glue
(C.A. glue,super glue.)

L/R Assemble left and right
sides the same way.

 Ensure smooth non-binding
movement while assembling.

 Peel off shaded portion
covering film.

 Cut off shaded portion.

 Drill holes with the specified
diameter(here:3mm)

N.I. Must be purchased separately!

! Pay close attention here!

! **Warning!**

 Pierce the shaded portion
covering film.

Do not overlook this symbol!



Parts List

1. FUSELAGE -- 1pc.
2. MAIN WING -- 1 pair
3. STABILIZER & ELEVATOR -- 1 set
4. VERTICAL FIN & RUDDER -- 1 set
5. PILOT -- 1pc.
6. CANOPY -- 1set
7. ENGINE MOUNT PL5111070 -- 1 set
8. FUEL TANK 380cc -- 1 set
9. COWLING -- 1 pc.
TRANSPARENT 3D TEMPLATE -- 1 pc.
10. SPINNER Ø89mm -- 1 pc.
11. SPONGE 10 x 80 x 200 mm (For Radio Equipment) -- 2 pcs
12. MAIN LANDING GEAR -- 1 set
13. MAIN LANDING GEAR COVER -- 1 set
14. MAIN WHEEL Ø76mm -- 1 pair
15. TAIL LANDING GEAR -- 1 set
16. TAIL WHEEL Ø25mm -- 1 pc.
17. PUSHROD & PULLWIRE:--
Y-Type METAL ROD Ø1.8 x 110 mm
w/Threads (For Flap) -- 1 pc.
METAL ROD Ø1.8 x 85 mm w/Threads (For Aileron) -- 2 pc
METAL ROD Ø1.8 x 690 mm w/Threads (For Elevator) -- 1
METAL ROD Ø1.8 x 700 mm w/Threads (For Rudder) -- 1 p
18. THROTTLE PUSHWIRE Ø1.2 x 400 mm
w/Plastic tube d2 x D3 x 220mm -- 1 set
19. WOODEN PARTS:--
BALSA 5 x 5 x 37 (For Throttle Servo) -- 2 pcs
BALSA 5 x 5 x 49 (For Elevator & Rudder Servos) -- 2 pcs
BALSA 8 x 18 x 21 (For Aileron Servo) -- 4 pcs
BALSA 80 x 103mm (Wing Protection) -- 1 pc.
PLYWOOD 2 x 58 x 84mm (Aileron Servo Stand) -- 2 pcs
PLYWOOD 2.7 x 37 x 99mm (Throttle Servo Stand) -- 1 pc.
PLYWOOD 5.4 x 61 x 99mm (Elevator & Rudder Servos
Stand) -- 1 pc.
20. PLASTIC PARTS:--
CLEVIS -- 6 PCS
SILICON GROMMET d1.5 x D6.5mm
(For Cowling & Canopy) -- 8 pcs
STRAPER -- 4 pcs
TRI - HORN M3 x 14mm(L) -- 2 sets
TRI - HORN M3 x 14mm(S) -- 2 sets
RING 2.6mm -- 2 pcs
DOUBLE-SIDED TAPE -- 1 pc.
21. METAL PARTS:--
LINKAGE CONNECTOR -- 4 sets
COLLAR 2.1mm -- 1 set
COLLAR 4.6mm -- 2 sets
ALUMINUM PLATE (For Tail Landing Gear) -- 1 pc.
WING TUBE Ø16 x 390mm -- 1 pc.
NUT 2mm -- 9 pcs
NUT 3.5mm 8 pcs
SCREW PA 3 x 12mm -- 2 pcs
SCREW PM 2 x 6mm -- 8 pcs
SCREW PM 2 x 12mm -- 1 pc.
SCREW PM 2 x 14mm -- 3 pcs
SCREW PM 2 x 18mm -- 3 pcs
SCREW PM 2 x 25mm -- 6 pcs
SCREW PM 3.5 x 30m -- 4 pcs
SCREW PM 4 x 25mm -- 4 pcs
SCREW PM 4 x 40mm -- 2 pcs
SCREW PWA 2 x 12mm -- 8 pcs
SCREW PWA 2.3 x 8mm -- 12 pcs
SCREW PWA 2.6 x 12mm -- 4 pcs
WASHER 2 mm -- 8 pcs
WASHER d3.5 x D8mm -- 8 pcs
WASHER d4 x D12mm -- 4pcs
WASHER d4 x D15mm -- 2 pcs
22. FUEL TUBE Ø6 x 5mm -- 10pcs
23. DECALS -- 1 set

1 Aileron

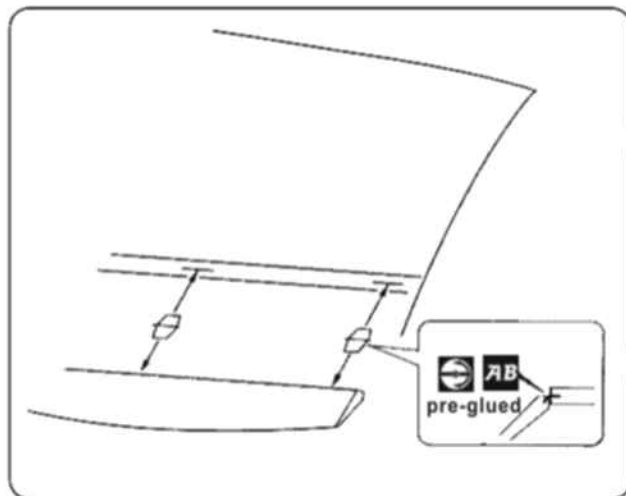

L/R

2 Aileron Servo

PWA2 x 12mm Screw

PM2 x 25mm Screw

Metal Rod $\varnothing 1.8 \times 85\text{mm}$

Balsa 8 x 18 x 21mm

Plywood 2 x 58 x 84 mm

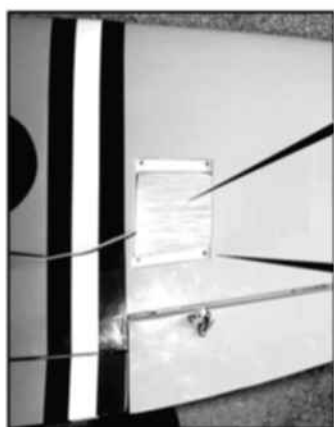

N.I.

AB

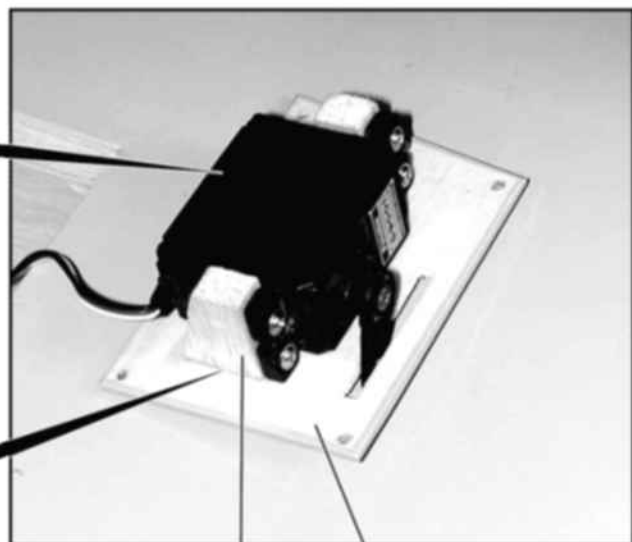

Balsa 8 x 18 x 21mm

Plywood 2 x 58 x 84 mm

Metal Rod $\varnothing 1.8 \times 85\text{mm}$

PWA 2 x 12mm

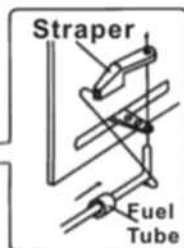
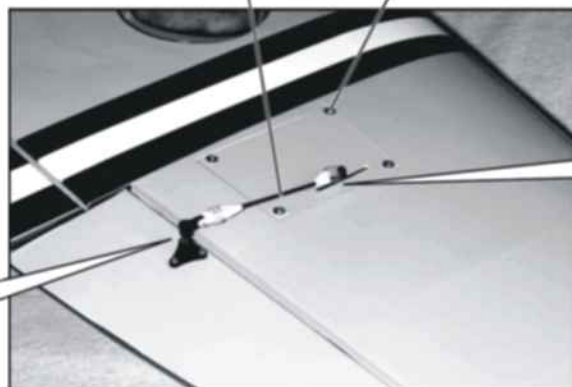
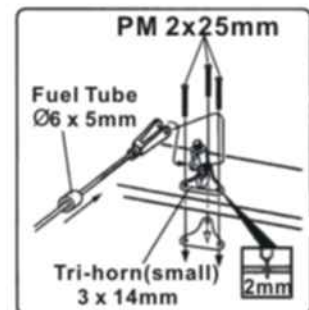

L/R

3 Flap and Retract Servos

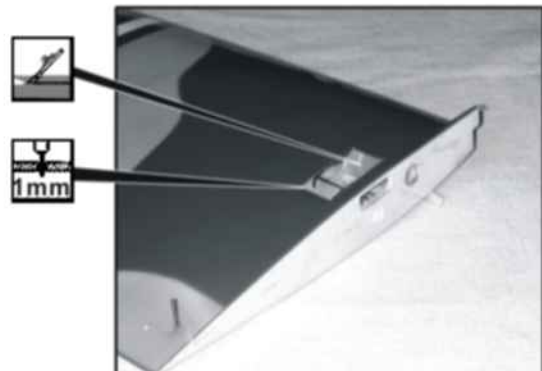
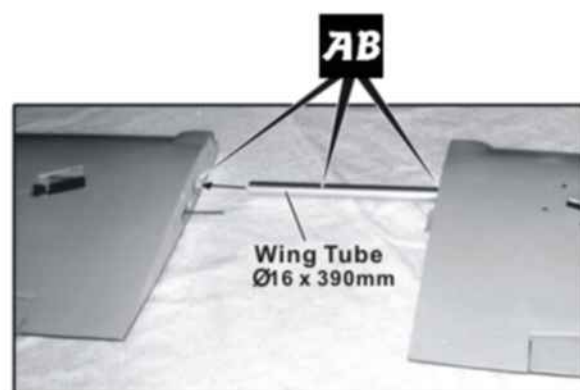

- Select the servo horn that will give 26mm travel when rotates through 180°

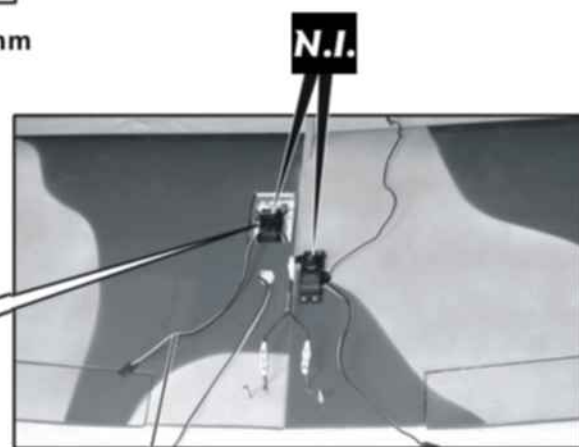
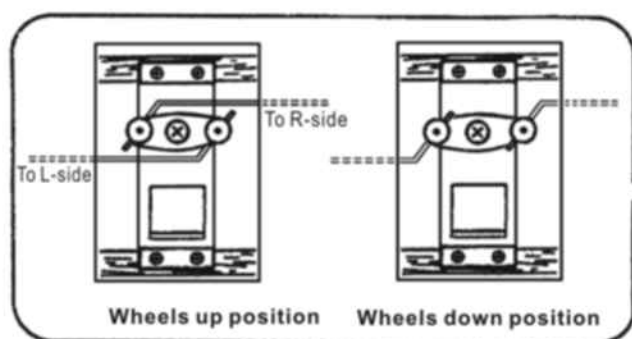

Lead to retract servo

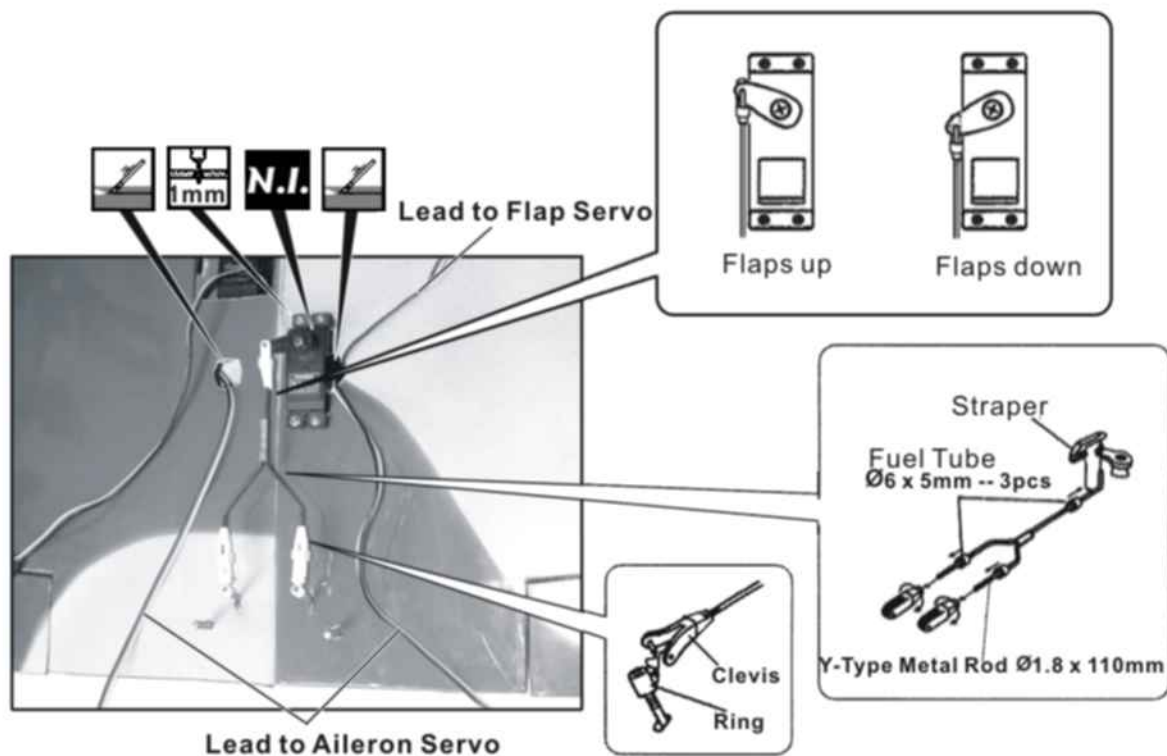

4 Landing Gear

● Bottom View

PWA 2.3 x 8mm Screw



8

PM 2 x 6mm Screw



8

2mm Washer

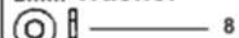

8

2mm Nut



8

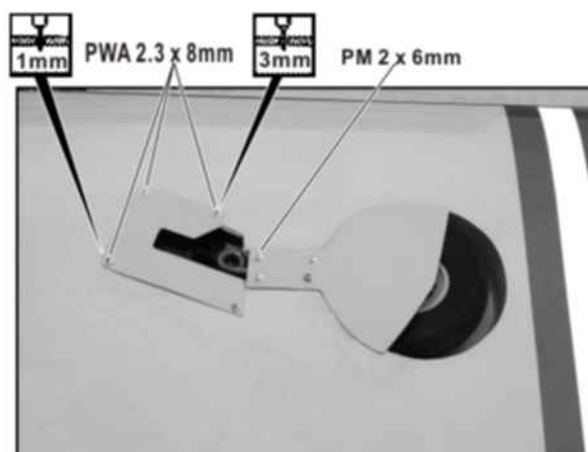
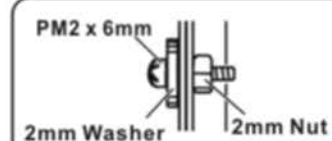

L/R

5 Stabilizer / Elevator

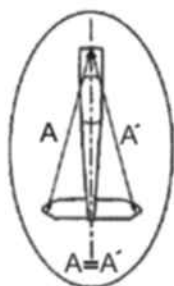

AB

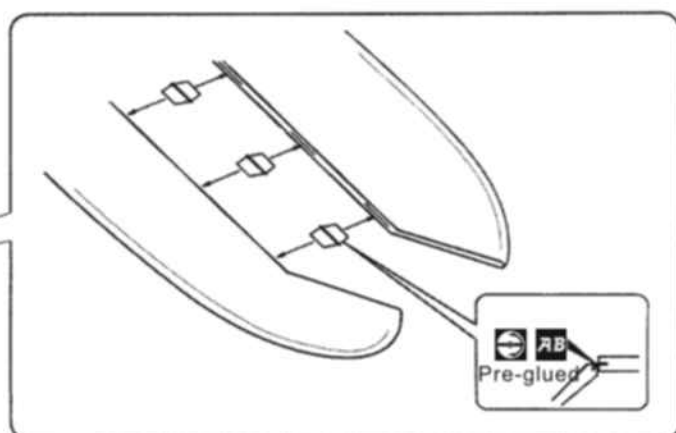
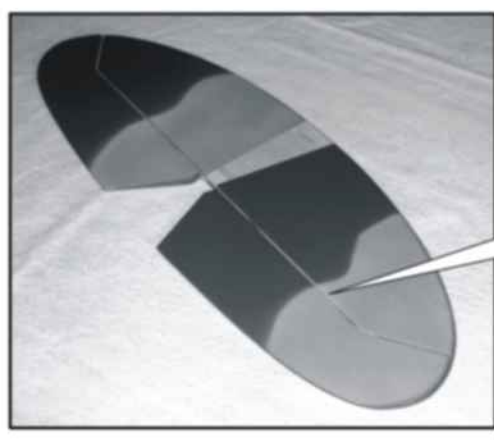
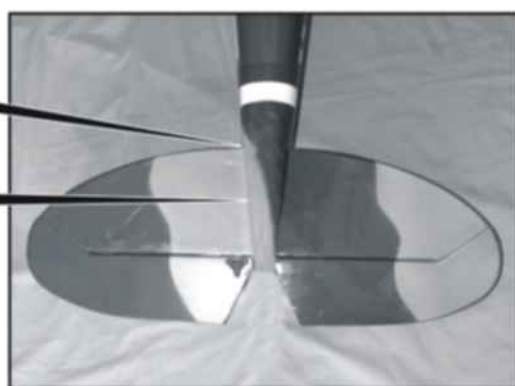

6 Vertical Fin / Rudder

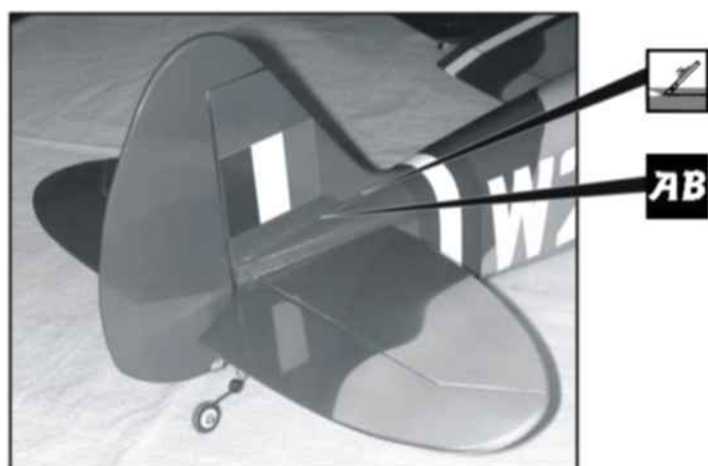
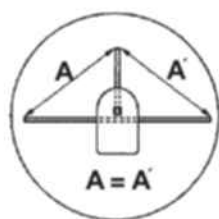
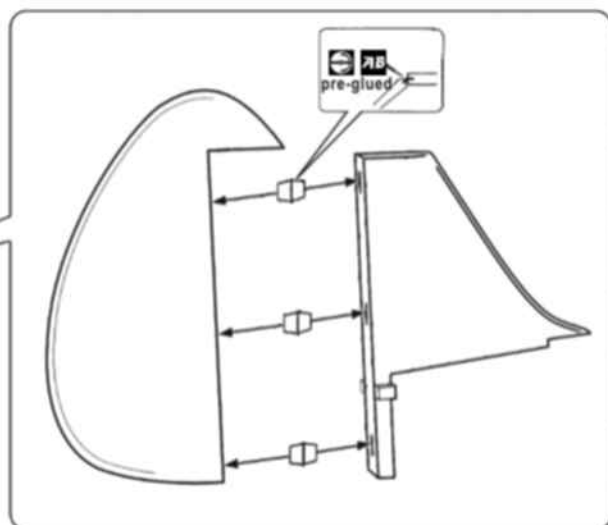
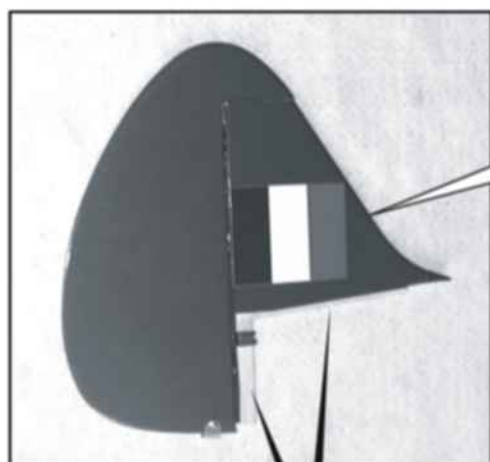

7 Elevator Pushrod

PM2 x 18mm Screw

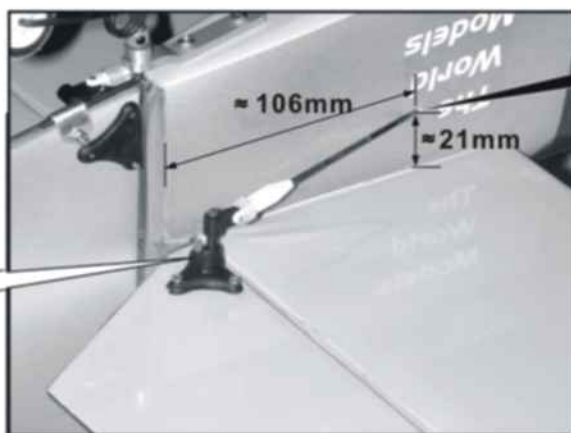
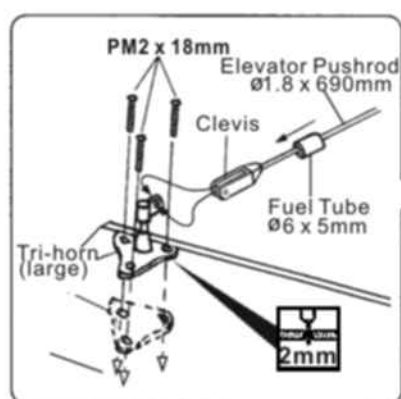

● Bottom View

8 Rudder Pushrod / Tail Gear

PM2 x 12mm Screw	1
PM2 x 14mm Screw	3
2mm Nut	
	1
PA3 x 12mm Screw	2
3mm Set screw	1
2.1mm Wheel Collar	1

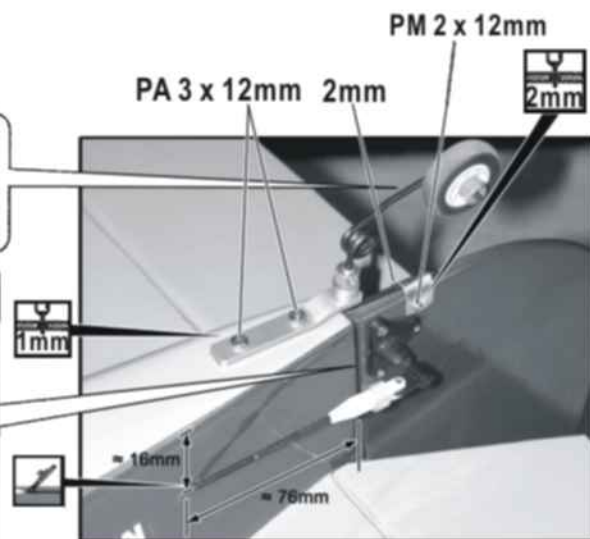
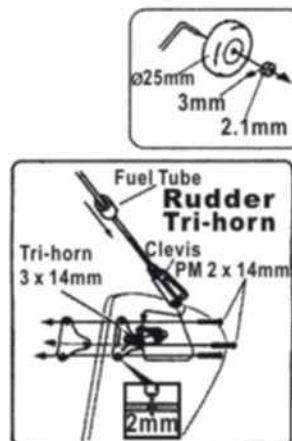

9 Fuel Tank

Plywood 2.7 x 37 x 99mm

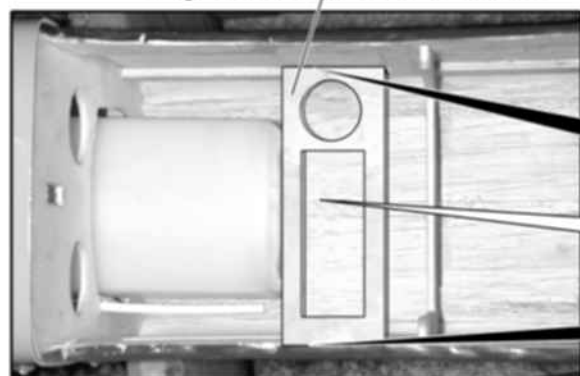

●Bottom View

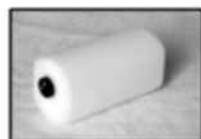

Install Plywood 2.7 x 37 x 99mm
(For fixing fuel tank)

Fuel Tank
380cc

●Bottom View

10 Engine Mount

PM4 x 25mm Screw	4
d4 x D12mm Washer	4

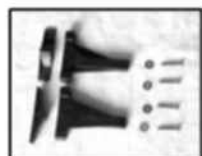

●Apply thread locker to screws.

d4 x D12mm

PM4 x 25mm

Engine Mount
PL5111070

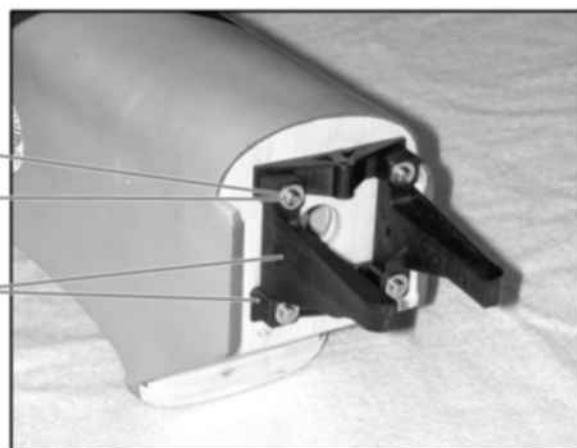

! Blind nuts are off-centered to keep the spinner at the fuselage axis.

11 Engine

PM 3.5 x 30mm Screw



d3.5xD8mm Washer



3.5mm Nut



3.5mm Nut
d3.5xD8mm
PM 3.5 x 30mm

Plastic Tube
d2xD3x220mm

Throttle Pushwire
Ø1.2 x 400mm



• Install Engine position

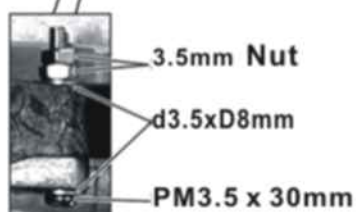

! Illustration is for inverted mounting. You can mount the engine upright or sideways simply by rotation the engine mount. Thrust angles will not be affected.

L/R

12 Cowling

PWA2.6 x 12mm Screw



d1.5xD6.5mm Silicon Grommet



PWA2.6 x 12mm

Silicon Grommet
d1.5xD6.5mm



L/R

• First insert the grommet to the cowling then apply screw.

13 Servo Set

LINKAGE CONNECTOR	
3 x 3mm Set Screw	4
Linkage Connector	4
2mm Nut	4
2mm Washer	4

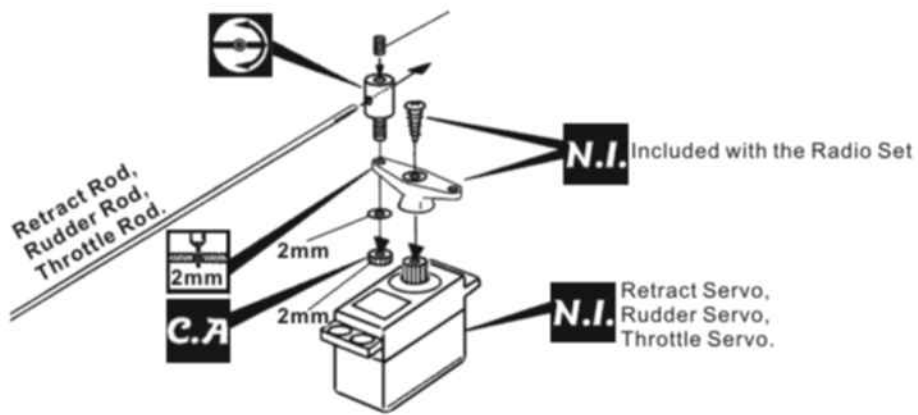

! Please refer to attached sheet for linkage connector installation.

14 Servos

● Install and arrange the servo as shown in the diagram.

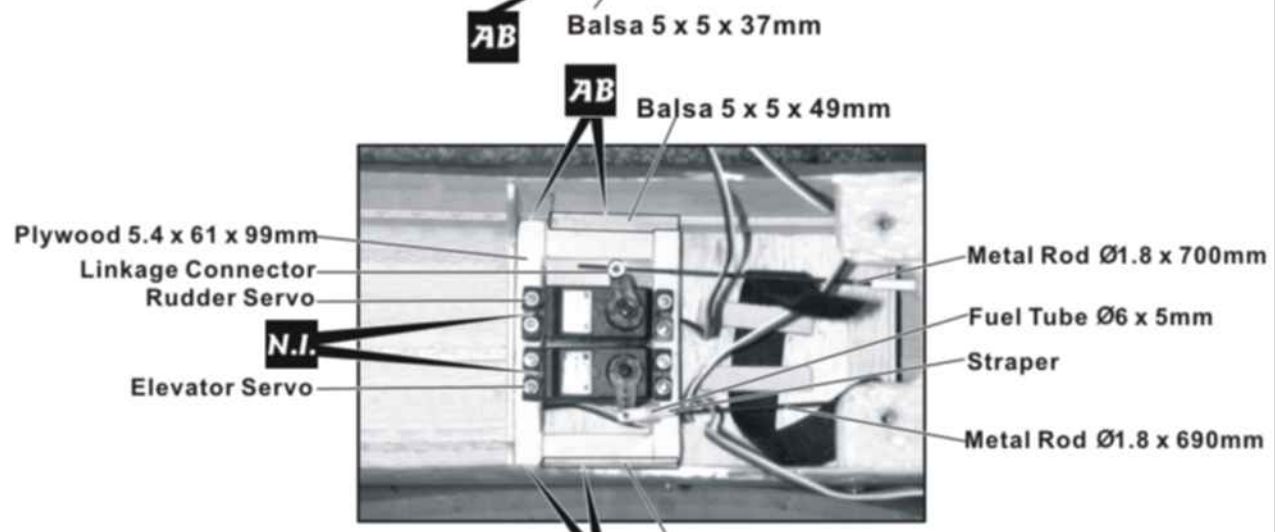
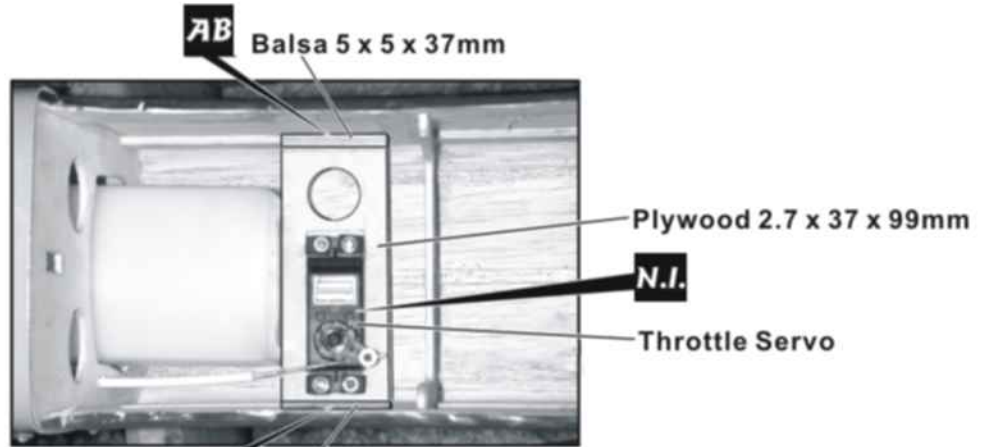

● Bottom View

15 Main Wing

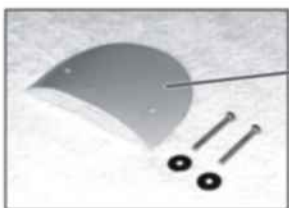
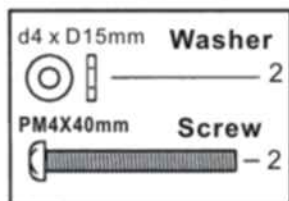

PM4X40mm
d4 x D15mm



16 Canopy

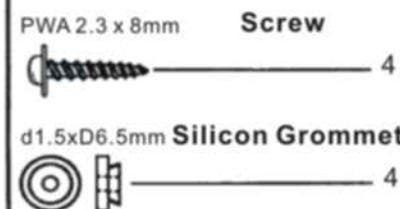

- Place canopy on fuselage and drill pilot holes.

Pilot

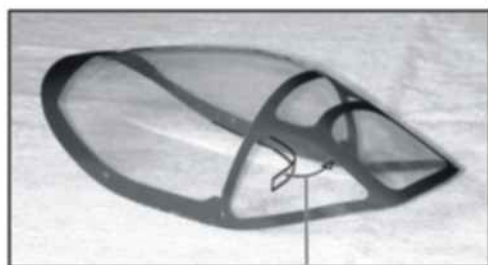
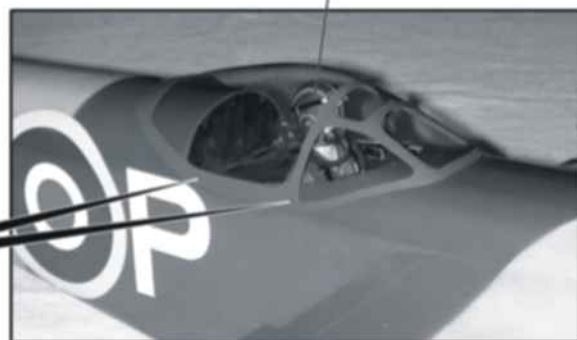

Apply double-sided tape



PWA 2.3 x 8mm
Silicon Grommet
d1.5xD6.5mm



- First insert the grommet to the canopy then apply screw

17 Wing Setting

Adjust the wing and fuselage configuration as in the diagrams.

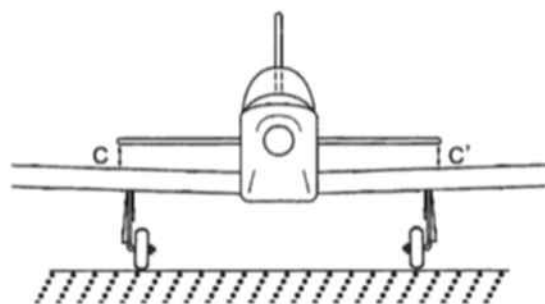
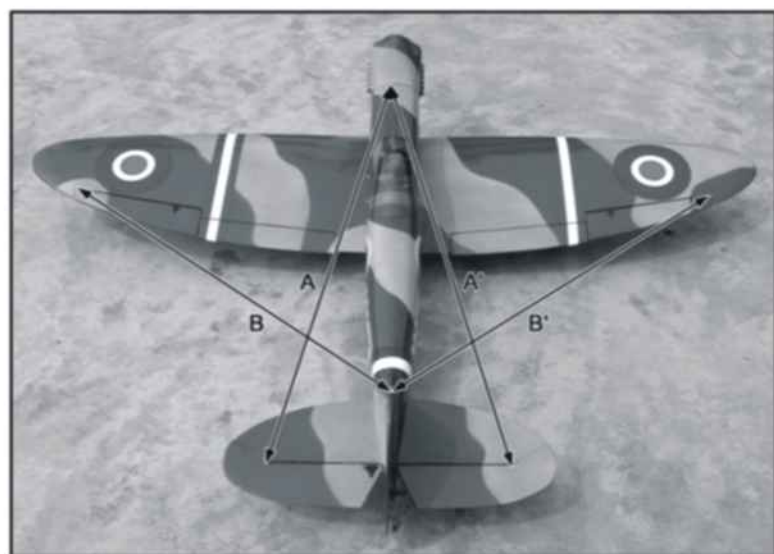

$A = A'$

$B = B'$

$C = C'$

18 Control Throws

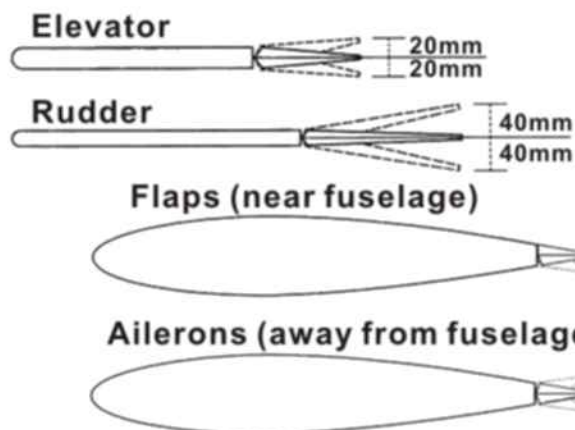

Adjust the control throws as shown in the diagram. These throws are good for general flying. You can adjust according to your personal preference.

19 C.G.

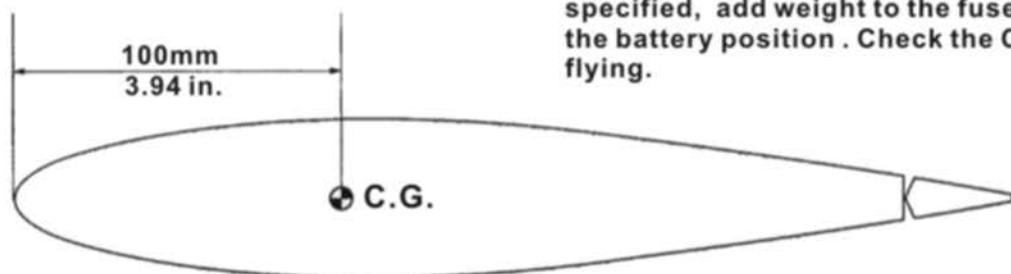

The ideal C.G. Position is 100mm (3.94 in) behind the leading edge measured at where the wing meets the fuselage. In order to obtain the C.G. specified, add weight to the fuselage or move the battery position. Check the C.G. before flying.

- Measure C.G. with the wheels in retracted position.

! Warning!

Important Safety Precautions

- #First time flyer should never fly by himself / herself. Assistance from experienced flyer is absolutely necessary.
- #Pre-flight adjustment must be done before flying, it is very dangerous to fly a badly pre-adjusted aircraft.
- # **SPITFIRE** is specially designed to be powered by 0.60 2 stroke or 0.70 4 stroke glow engine, using a more powerful engine does not mean better performance. In fact, over powered engine may cause severe damage and injuries.
- #Make sure the air field is spacious, never fly the plane too close to people and never get too close to a running propeller.
- #If you find wrinkles on the covering as a result of weather changes, you can use hot iron to remove the wrinkles. Please begin with lower temperature setting and gradually raise the temperature until the wrinkles are gone. Too hot an iron may damage the covering.
- #Check and re-tighten up all factory assembled screws, use thread locker if applicable.

ADDENDUM

LINKAGE CONNECTOR HW7111030 & HW7111060

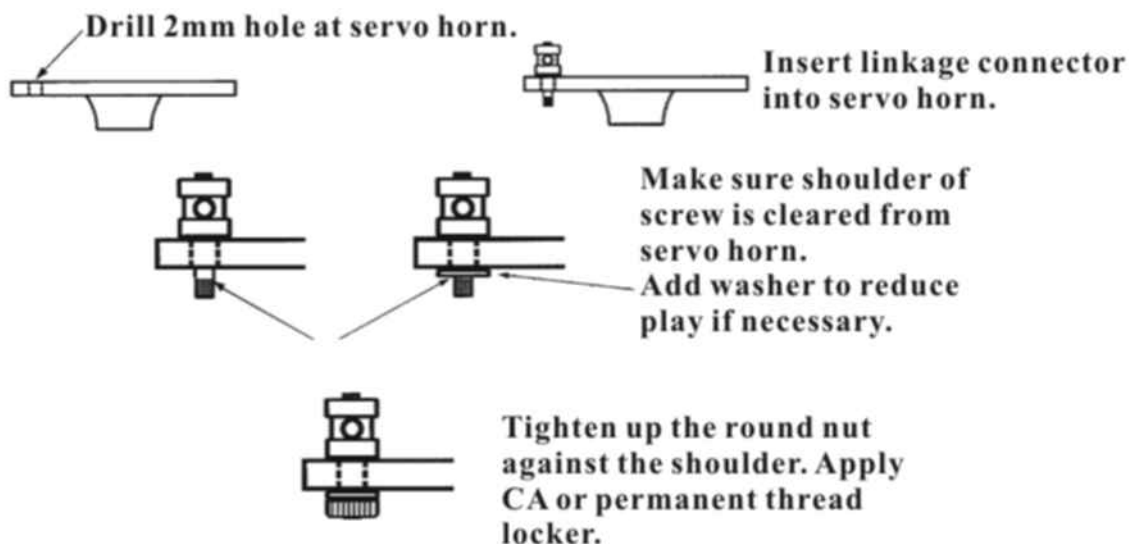

After fastening the round nut, make sure that the linkage connector can rotate freely.

When Flaps are lowered, nose of model will rise. The nose-up varies with the speed at which the model is flying when you lower the flaps and the extent to which they are lowered. Check effect of flaps at higher altitude to avoid surprises during landing. You may apply down trim of the elevator to compensate for the nose-up effect when lowering the flaps. Taking off with flaps lowered is not recommended, as the increased drag may require a longer runway and more engine power for the model.



Bob Bank's

AIRCRAFT DOCUMENTATION

Scale Model Research

3114 Yukon Avenue • Costa Mesa, CA 92626 U.S.A.

(714) 979-8058 FAX (714) 979-7279